

# NX series

The true Black LED display



## Key benefits:

- Phenomenal black levels
- Contrast ratio of 4000:1 for NX-4 and 4200:1 for NX-6
- Brightness output of 2000 Nit
- Seamless & lightweight
- 16-bit color & greyscales
- Consistent uniformity over time
- Creativity options
- Serviceable without tools
- Cross-rentable today and tomorrow
- Easy & fast set up
- High reliability

Barco introduces the next breakthrough in LED displays — the NX series, the industry's new visual standard in indoor LED technology. With its revolutionary Black LED, the NX delivers the deepest black levels of any product on the market.

But the new Black LED is only one element that makes the NX unique. Key advances in base materials, mechanical design and color processing have raised the bar of LED displays to new heights of image quality.

The NX is not simply an incremental advance in indoor LED tile technology — it's more, much more. In fact, the term "quantum leap" doesn't even come close.

**BARCO**

Visibly yours

## The elegant contradiction - black and bright

By far, the key factor that sets the NX apart from all other LED displays is immediately evident — even when the LEDs are turned off. With the NX, Barco has developed a true black LED — not just a black package, but a radically new design, from the interior resin to the exterior shaders.

Using black silicon resin instead of the traditional white epoxy, not only does the NX appear black, but each LED outputs the deepest blacks and brightest luminance levels of any product on the market. In addition, the NX's remarkable output is enhanced by a new "light-trap" shader

that combines a super-black shader casting with optimized geometry. The result — dramatically enhanced horizontal and vertical viewing angles, a significant reduction in light reflections and deeper black levels than ever before.

Is "black and bright" a contradiction? Yes — but a most elegant one, and only from Barco.

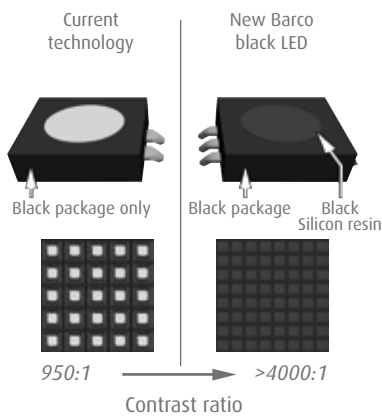

## Seamless and lightweight

Today's industry standard for mounting an LED wall is metal. While strong and roadworthy, metal frames are heavy and very sensitive to deformation. To complement the NX series' new LED display benchmark, Barco has engineered the industry's new structural benchmark — the "Mag-frame".

The Mag-frame is built of carbon fiber and is designed in a framework — rather than a box. The result is a support system far stronger, far lighter, and ten times less sensitive to deformation than the current "metal" structures. For added strength and fewer components, the structure uses optimized glue rather than screws, providing extremely tight tolerances along all three structural axes (x, y and z).

Not only is carbon fiber incredibly strong, it is also super light. The weight of the NX tile including structure and cables is 59kg/sqm, 21% less than ILite 6XP. For the crew, this translates into significant savings in terms of transportation, serviceability, and far less stress on the overhead truss.

Barco has also transformed the entire science of mounting the modules within the tile. With the Mag-frame, LED modules connect directly to the structure via high-strength neodymium "neo" magnets, rather than traditional screws. No tools are required for mounting or removal. With each magnet capable of holding over 1000 times its own mass, the result is precise positioning, super easy setup, and a totally seamless display.

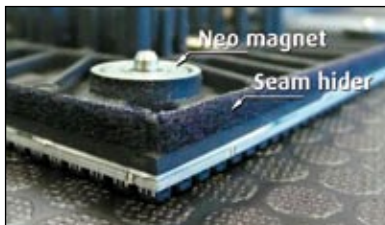

Neo magnet and seam hider

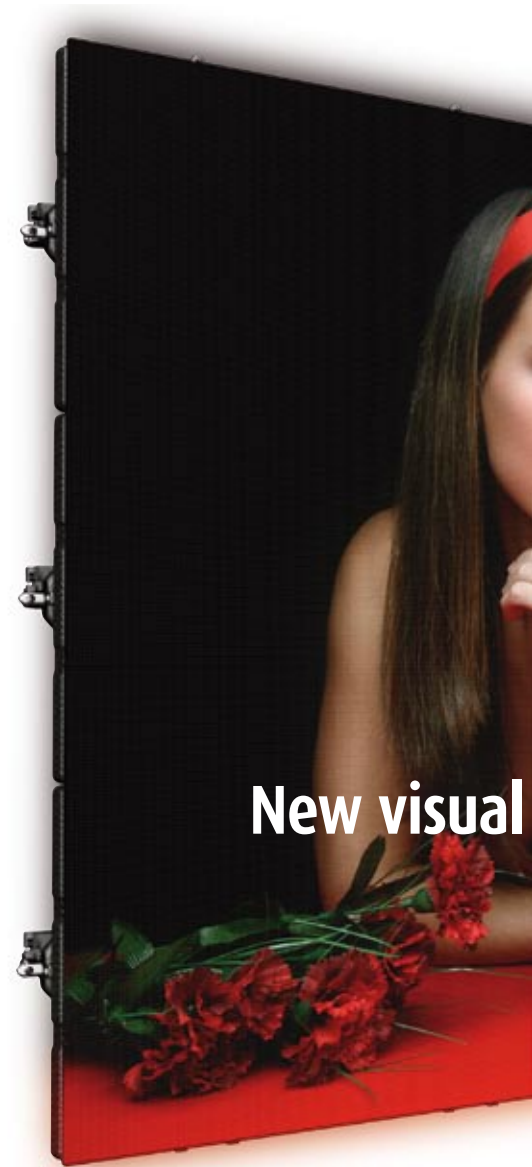

New Mag-frame

## Consistent uniformity over time

The NX's "black and bright" attributes will revolutionize the display industry, but not if the product's lifetime has to suffer as a result. To address this, Barco has engineered an "anti-aging" solution on three levels:

- By using next generation, highly efficient LED dies and by running the LEDs at lower temperatures, extremely high brightness levels have been achieved at much lower currents. It's simple — less stress equals longer life.
- Within the LED itself, the use of silicon instead of epoxy resin also slows the aging process, and provides a greater degree of reliability in humid operating conditions.
- The NX's new "tri-color" LED calibration further ensures display stability and uniformity over time.

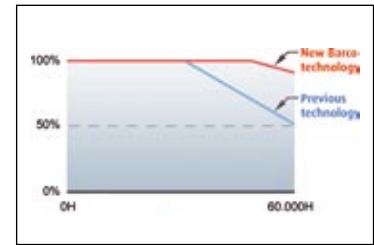

It's a fact that LEDs age, and their output declines in brightness over time. But with NX's technical advances, Barco has not only engineered an "anti-aging" solution, but a ROI solution as well — with the product's brightness declining to only 85% after 60,000 hours!



standard in LED displays

## Brilliant colors, breathtaking greyscales

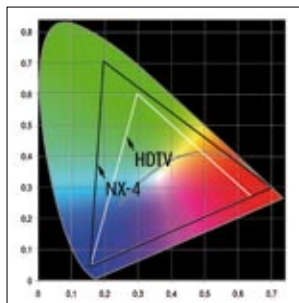

Color triangle of new 'Black LED'

With the introduction of the NX series, color processing advances to a new industry pinnacle — 16-bit processing and new "tri-color" calibration on all three colors simultaneously. Each NX LED can deliver up to 281 trillion colors, enabling tiles to reach staggering new levels of color depth, uniformity, and gray-scale range — a critical requirement for all low brightness applications.

With a tight selection of LEDs and the 16-bit processing power of the NX series, tiles can be calibrated to a larger color triangle — one that is actually wider than the HDTV standard,

delivering vibrant images with deep, uniform colors across the entire display surface. In combination with the DX-700, Barco's new 16-bit digitizer, the NX delivers more colors, more detail, and a higher degree of uniformity than ever before — without sacrificing color depth. Effectively, NX and DX-700 provide a brilliant "no compromise" system that must be experienced in person to fully appreciate — print simply does not do it justice!

## Native HD — by design

Each NX tile consists of nine modules, plus a single control unit, which also houses the power supply and interface board. NX tiles are 448mm wide by 504mm high (17.6 x 19.8 inches).

For NX-4, each tile's aspect ratio is 8:9. Place two tiles side-by-side and you're spot on 16:9 — and precisely ready for HD. Given a 20 x 10 tile array, your exact pixel resolution is 1920 x 1080 — the native HD resolution.

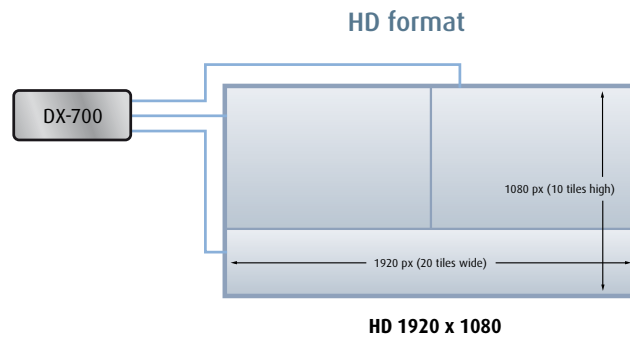

## Get creative

The NX series also employs the same small modular concept as Barco's renowned OLite series — allowing the tiles to be used either as a standard integral display, or split apart for creative designs. And when used in conjunction with Barco's Director Toolset, you can build displays of any shape or form — limited only by your imagination.

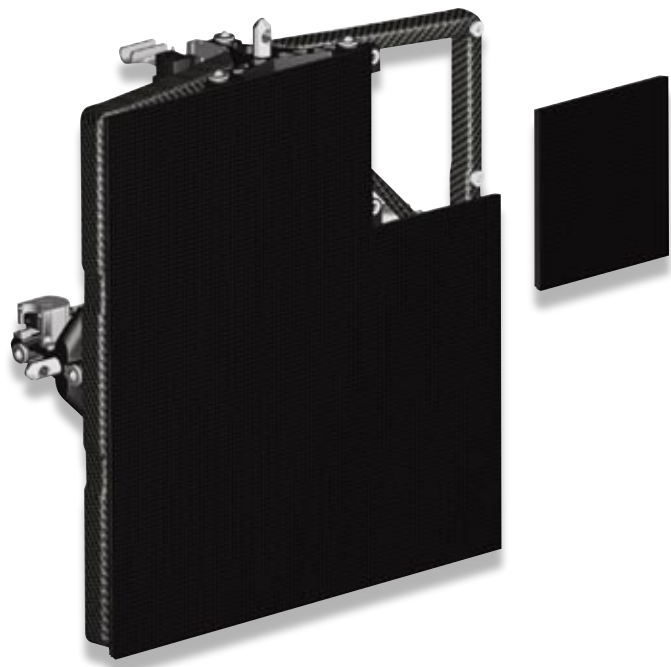
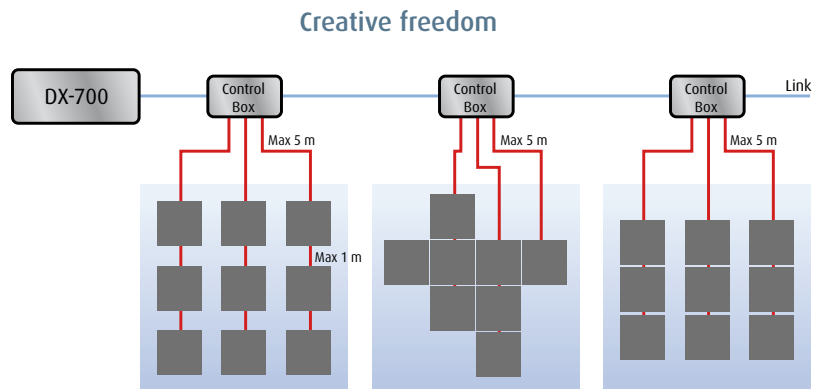

## Remove the tools, improve the serviceability

With the NX series, Barco designers have given you less to work with! That is, no tools or cables are required to set up and secure a NX LED wall, or take it apart for service. And because the Mag-frame is essentially an open structure, there's easy access to every module, the control unit and interface boards. The control unit can even be opened while the tile is fully operational. For added serviceability, if any shader is damaged, they are easily removed and replaced.

The inter-tile locking system has also been re-designed for ease of setup, with simplified electrical connections, accurate "click" prelocks, robust horizontal and vertical locking mechanisms — and (once again), no cables or tools required.

We give you less – to your distinct advantage!

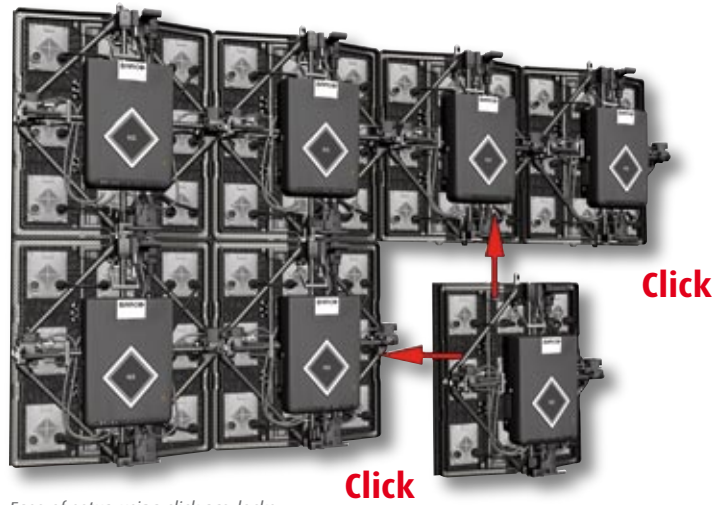

*Ease of setup using click pre-locks*



*Control unit can be opened while the tile is operational. The same control unit is used on both NX-6 and NX-4.*

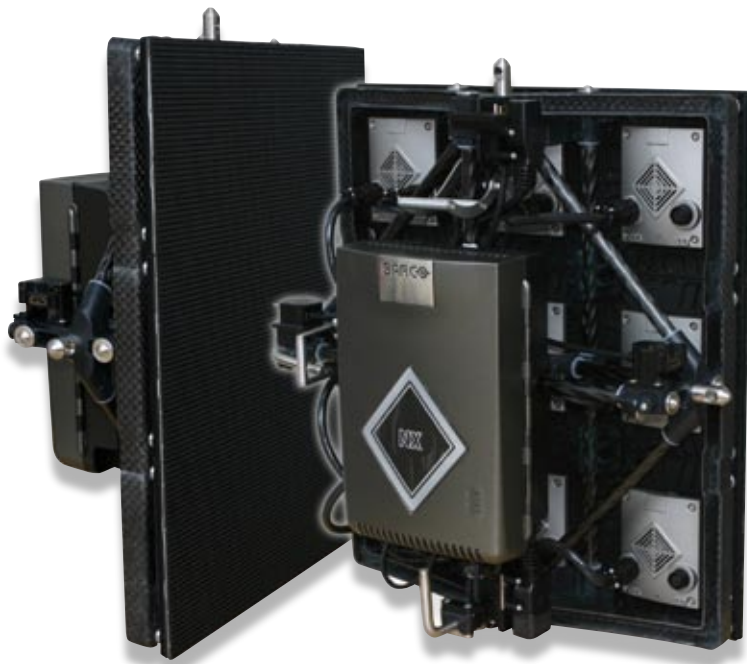

## DX-700 processor – purpose-built for the NX series

Barco's new DX-700 is a multi-window processor designed as a versatile, advanced digitizer for all current Barco LED products and all next generation platforms such as the NX series. With DVI output modules designed specifically for the current products (such as OLite 612 and I6XP), and new "NNI" output modules designed specifically for NX tiles, the DX-700 provides the power of 16-bit processing, modularity and multi-bank control.

The DX-700 is further enhanced with "universal" input modules that enable you to connect DVI (RGB or YCbCr), Dual-DVI (RGB), Component Analog (RGB or YPbPr), SD-SDI, HD-SDI, and Dual HD-SDI formats.

You can also configure a single DX-700 with multiple input and output modules, in a variety of creative configurations or link multiple DX-700's together for larger, more complex setups.



### Additional DX-700 features include:

- 16-bit processing
- 10-bit color depth, in either 4:4:4 or 4:2:2 input format
- Motion-adaptive de-interlacing
- Dynamic contrast enhancement on any input source
- Input adjustments, including saturation, balance and sharpness
- Seamless transitions between inputs
- Color-keying
- Digital video effects, including freeze, strobe and linear color transformations
- Comprehensive "wizards" for input and output setup
- Presets storage and recall

... and so much more. With DX-700 in your system, not only will your NX tiles shine with the full spectrum of color and detail, but your *legacy* Barco tiles will appear more brilliant than ever before.

## Fiberlink NNI

The Fiberlink NNI is a newly designed Multi Mode fiber optic system, enabling the user to extend the distance between the DX-700 NNI output card and an NX series display - as well as the between two NX displays. The maximum distances of 300m can be bridged using the Fiberlink NNI system.

Both the TX (Transmitter) and RX (Receiver) are IP65 rated, and have also been specially designed to work under high temperatures (up to 50°C / 122°F).

All cables (including the fiber cable) are field replaceable.



## Director Toolset

### Advanced installation and control software

Barco's Director Toolset is an integrated software package which provides an intuitive, graphical interface for fast installation, system calibration, layout configuration and display control.

As a modular application, the Director Toolset is now easier and faster to update and manage in the field. Key features include:

#### Configuration module

- Improved management system (copy, delete, save etc.)
- Complete projects can be created off-line
- Easy to switch between different setups (configurations)
- Clear connectivity overview
- Group presets, enabling you to recall presets on different displays simultaneously
- Direct access to all devices (LED, Digitizer, Fiber, AEC)
- Exchange presets between DX-700 and DTS
- Store and recall projects from DX-700

#### Tile position module

- Selectable positioning method (auto or manual)
- Improved manual/creative positioning method
- Ability to configure creative wall configurations
- Ability to split displays into segments (e.g. long tickertapes, multiple walls driven by a single processor)

#### Operations module

- Easy copy of setting (viewport & window)
- Selectable color/window and picture insertion
- Easy setup/recall of presets via preview/live window
- Undo/redo function
- New integrated stack manager, enabling you to easily manage stacked configurations

#### Monitoring module

- Semi automatic bug reporting tool
- Configuration report generation

#### IX module

- Creative design module for NX modules, MiTRIX, MiSTRIP and OLite modules

#### Basic module (new)

- An easy setup wizard which enables users to set up LED displays, align input sources and create presets with ease

#### General features

- Configuration report generation
- Automatic software/firmware downloads functionality (new)
  - Automatically scans and downloads the latest software and firmware from a secured web server
  - Eliminates the need to access the Partner Zone in order to have the latest code



New configuration module

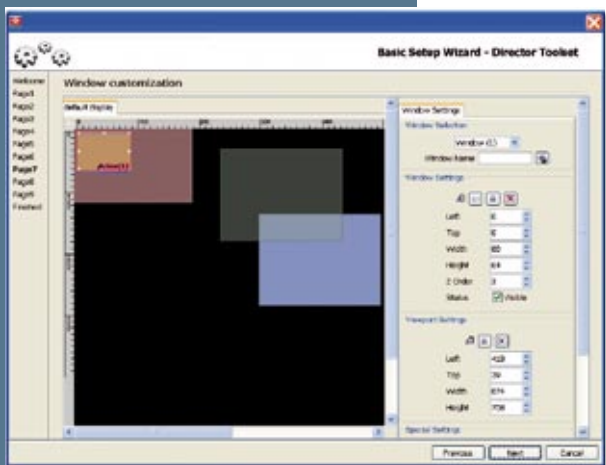

New basic module

## Specifications

	NX-4	NX-6
<b>Pixel pitch</b>	4.6 mm	6.2 mm
<b>Brightness<sup>(1)</sup></b>	2,000 Nit	2,000 Nit
<b>LED configuration</b>	3-in-1 SMD	3-in-1 SMD
<b>Pixel density</b>	45,931/sqm 4,271/sqf 10,368 (96 x 108)/tile	25,847/sqm 2,403/ft2 5,832 (72 x 81)/tile
<b>Viewing angle<sup>(2)</sup></b>	hor: 120 degree vert: +48, -55 degree	hor: 120 degree vert: 120 degree
<b>Contrast ratio</b>	4,000:1	4,200:1
<b>Lifetime<sup>(3)</sup></b>	60,000H	60,000H
<b>Power consumption</b>	300W max 132W average	330W max 145W average
<b>Weight / tile</b>	12.9 kg (incl. structure, cable) 28.4 lbs (incl. structure, cable)	12.9 kg (incl. structure, cable) 28.4 lbs (incl. structure, cable)
<b>Processing</b>	16 bit/color	16 bit/color
<b>Colors</b>	281 trillion	281 trillion
<b>Refresh rate</b>	3,200 Hz	3,200 Hz
<b>Operating temperature</b>	0 - 40 degree	0 - 40 degree
<b>Storage temperature</b>	-20 - 60 degree	-20 - 60 degree
<b>Operating humidity</b>	35 - 85 %	35 - 85 %
<b>Storage humidity</b>	10 - 90 %	10 - 90 %
<b>Source compatibility</b>	CVBS, YC, YUV, RGB, DVI (Single and Dual Link, up to 2048x1536), SDI, HD-SDI, Dual link HD-SDI	
<b>Certification</b>	CE class A, TUV, FCC Class A, ETL, Cebec	
<b>Order number</b>	R9052771	R9052780

(1) display calibrated at 6500°K

(2) at min 50 % brightness

(3) full white, 75 % brightness

## Dimensions

### Tile

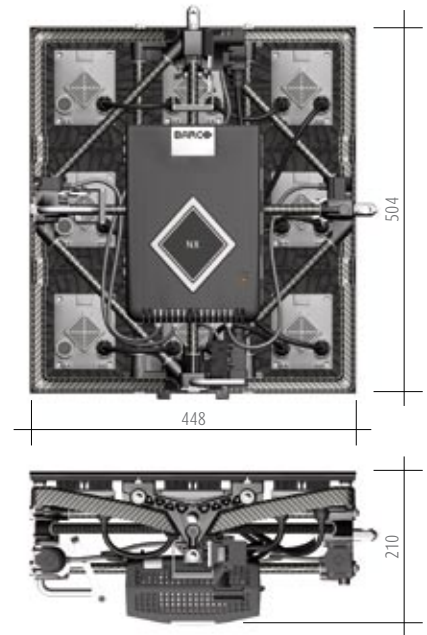

### Module

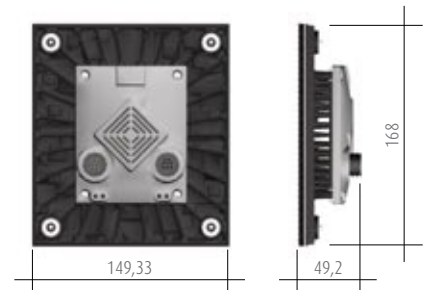

### Barco nv - Media & Entertainment Division

Noordlaan 5, 8520 Kuurne, Belgium  
T +32 56 36 80 47 - F +32 56 36 83 86  
email: sales.event@barco.com

11101 Trade Center Drive,  
Rancho Cordova, CA 95670, USA  
T +1 916 859 2500 - F +1 916 859 2515